

BALDOR® • RELIANCE 

Product Information Packet

VEBM3546-5S

1HP,1760RPM,3PH,60HZ,56C,3520M,TEFC,F3,B

Part Detail							
Revision:	J	Status:	PRD/A	Change #:		Proprietary:	No
Type:	AC	Elec. Spec:	35WGM849	CD Diagram:	CD0006	Mfg Plant:	
Mech. Spec:	35X055	Layout:	35LYX055	Poles:	04	Created Date:	03-06-2015
Base:	N	Eff. Date:	03-14-2019	Leads:	3#18		

Specs			
Catalog Number:	VEBM3546-5S	Insulation Class:	F
Enclosure:	TEFC	Inverter Code:	Inverter Ready
Frame:	56C	KVA Code:	L
Frame Material:	Steel	Lifting Lugs:	No Lifting Lugs
Output @ Frequency:	1.000 HP @ 60 HZ	Locked Bearing Indicator:	Locked Bearing
Synchronous Speed @ Frequency:	1800 RPM @ 60 HZ	Motor Lead Quantity/Wire Size:	3 @ 18 AWG
Voltage @ Frequency:	575.0 V @ 60 HZ	Motor Lead Exit:	Ko Box
XP Class and Group:	None	Motor Lead Termination:	Flying Leads
XP Division:	Not Applicable	Motor Type:	3520M
Agency Approvals:	CE	Mounting Arrangement:	F3
	CSA	Power Factor:	71
	CSA EEV	Product Family:	General Purpose
	UR	Pulley End Bearing Type:	Ball
	WEEE	Pulley Face Code:	C-Face
Auxillary Box:	No Auxillary Box	Pulley Shaft Indicator:	Standard
Auxillary Box Lead Termination:	None	Rodent Screen:	None
Base Indicator:	No Mounting	Shaft Extension Location:	Pulley End
Bearing Grease Type:	Polyrex EM (-20F +300F)	Shaft Ground Indicator:	No Shaft Grounding

Blower:	None	Shaft Rotation:	Reversible
Current @ Voltage:	1.200 A @ 575.0 V	Shaft Slinger Indicator:	No Slinger
Design Code:	B	Speed Code:	Single Speed
Drip Cover:	No Drip Cover	Motor Standards:	NEMA
Duty Rating:	CONT	Starting Method:	Direct on line
Electrically Isolated Bearing:	Not Electrically Isolated	Thermal Device - Bearing:	None
Feedback Device:	NO FEEDBACK	Thermal Device - Winding:	None
Front Face Code:	Special Combinations Not Liste	Vibration Sensor Indicator:	No Vibration Sensor
Front Shaft Indicator:	None	Winding Thermal 1:	None
Heater Indicator:	No Heater	Winding Thermal 2:	None

Nameplate NP2934L	
CAT.NO.	VEBM3546-5S
SPEC.	35X055M849G1
HP	1
VOLTS	575
AMP	1.2
RPM	1760
FRAME	56C
HZ	60
PH	3
SER.F.	1.15
CODE	L
DES	B
CL	F
NEMA-NOM-EFF	85.5
PF	71
RATING	40C AMB-CONT
CC	010A
DE	6205
ODE	6205
USABLE AT 208V	
ENCL	TEFC
SN	
IP22, BRK 6 FT-LB	

Parts List		
Part Number	Description	Quantity
SA295124	SA 35X055M849G1	1.000 EA
RA281193	RA 35X055M849G1	1.000 EA
NS2512A01	INSULATOR, CONDUIT BOX X	1.000 EA
35CB4007	KOBX,W/PRIMER (REL# 79097-49-C)	1.000 EA
35GS3009	GASKET, KOBX 35CB4006 (411881-15A)	1.000 EA
51XB1016A05	10-16X5/16HX WA SL SR TYB (F/S)	2.000 EA
WD4101A13	STEEL CAPLUG,BP-1 1/8, PLUG D3561S	1.000 EA
11XW1032G06	10-32 X .38, TAPTITE II, HEX WSHR SLTD U	1.000 EA
HW3001B02	BRASS CUP WASHER W/GROUND SYMBOL TAB,	1.000 EA
HW5100A05	WVY WSHR F/205 & 304 BRGS	1.000 EA
35EP3307F00	MASTER DE,205 BRG,.998SH,#26 DRN	1.000 EA
51XN1032A20	10-32 X 1 1/4 HX WS SL SR	2.000 EA
HW1001A10	WASHER, #10 SPLT LK, ZN X	4.000 EA
HW2501D13	KEY, 3/16 SQ X 1.375	1.000 EA
HW2501D13	KEY, 3/16 SQ X 1.375	1.000 EA
BR2003D01	SPLINED HUB 7/8 W/O KEY, W/SET SCREWS	1.000 EA
35FN3003A02	EXFN, PLASTIC, 5.88 OD, .876 ID (REL)	1.000 EA
35FH4007A01	FAN COVER FOR SHORT SERIES BRAKE, PRIMER	1.000 EA
51XW1032A06	10-32 X .38, TAPTITE II, HEX WSHR SLTD S	4.000 EA
35CB4519	CB LID W/BLACK PRIMER	1.000 EA
35GS3019A01	LEXIDE GASKET, FOR KOBX LID 35CB4519	1.000 EA
51XW0832A07	8-32 X .44, TAPTITE II, HEX WSHR SLTD SE	4.000 EA
WD4006A01	WIRE JOINT,T&B RB-4 OR RB-44	1.000 EA
HA7000A04	KEY RETAINER 0.625 DIA SHAFTS	1.000 EA

Parts List (continued)		
Part Number	Description	Quantity
85XU0407S04	4X1/4 U DRIVE PIN STAINLESS	2.000 EA
LB1418	INTEGRAL BRK ADJ LABEL (REL# 41171617A)	1.000 EA
MJ1000A02	GREASE, MOBIL POLYREX EM - 124047	0.050 LB
MG1025N19	MUNSELL 8.5BG 3.57/2.0, GLOSS 30, B/G,	0.017 GA
LB1419	CONNECTION LABEL	1.000 EA
HA3100A13	THRUBOLT 10-32 X 7.750	4.000 EA
43BK0200B03	SSB-6-287/575 (205) L HUB	1.000 EA
LB1424A03	BRAKE VOLT LABEL 287/575V SSB	1.000 EA
LB1119N	WARNING LABEL	1.000 EA
LC0006	CONNECTION LABEL	1.000 EA
NP2934L	ALUM SUPER-E UL CSA-EEV CE CC PREM	1.000 EA
36PA1000	PKG GRP, PRINT PK1016A06	1.000 EA
PK3082	STYROFOAM CRADLE	1.000 EA
MN416A01	TAG-INSTAL-MAINT no wire (1200/bx) 3/19	1.000 EA
PE-0000001	ZRTG PE ASSEMBLY	1.000 EA

AC Induction Motor Performance Data

Record # 32073 - Typical performance - not guaranteed values

Winding: 35WGM849-R001	Type: 3520M	Enclosure: TEFC
-------------------------------	--------------------	------------------------

Nameplate Data				575 V, 60 Hz: Single Voltage Motor	
Rated Output (HP)	1			Full Load Torque	2.99 LB-FT
Volts	575			Start Configuration	direct on line
Full Load Amps	1.2			Breakdown Torque	13.3 LB-FT
R.P.M.	1760			Pull-up Torque	8.11 LB-FT
Hz	60	Phase	3	Locked-rotor Torque	8.38 LB-FT
NEMA Design Code	B	KVA Code	L	Starting Current	9.77 A
Service Factor (S.F.)	1.15			No-load Current	0.84 A
NEMA Nom. Eff.	85.5	Power Factor	71	Line-line Res. @ 25°C	23.9 Ω
Rating - Duty	40C AMB-CONT			Temp. Rise @ Rated Load	36°C
S.F. Amps				Temp. Rise @ S.F. Load	42°C
				Locked-rotor Power Factor	53.9
				Rotor inertia	0.118 LB-FT ²

Load Characteristics 575 V, 60 Hz, 1 HP

% of Rated Load	25	50	75	100	125	150	S.F.
Power Factor	29	47	60	69	76	80	75
Efficiency	74.4	83.2	85.2	85.9	85.3	84.4	85.5
Speed	1790	1780	1770	1760	1748	1735	1754
Line amperes	0.872	0.977	1.1	1.26	1.46	1.68	1.35

Performance Graph at 575V, 60Hz, 1.0HP Typical performance - Not guaranteed values

ABB Motors and Mechanical Inc.

WINDING # 35WGM849

Typical performance - not guaranteed values.

1 HP 3 PH 60 HZ 1760 RPM 575 V 3520M

TORQUES(LB-FT): PO=13.3 PU=8.11 LR=8.38 LRA=9.77

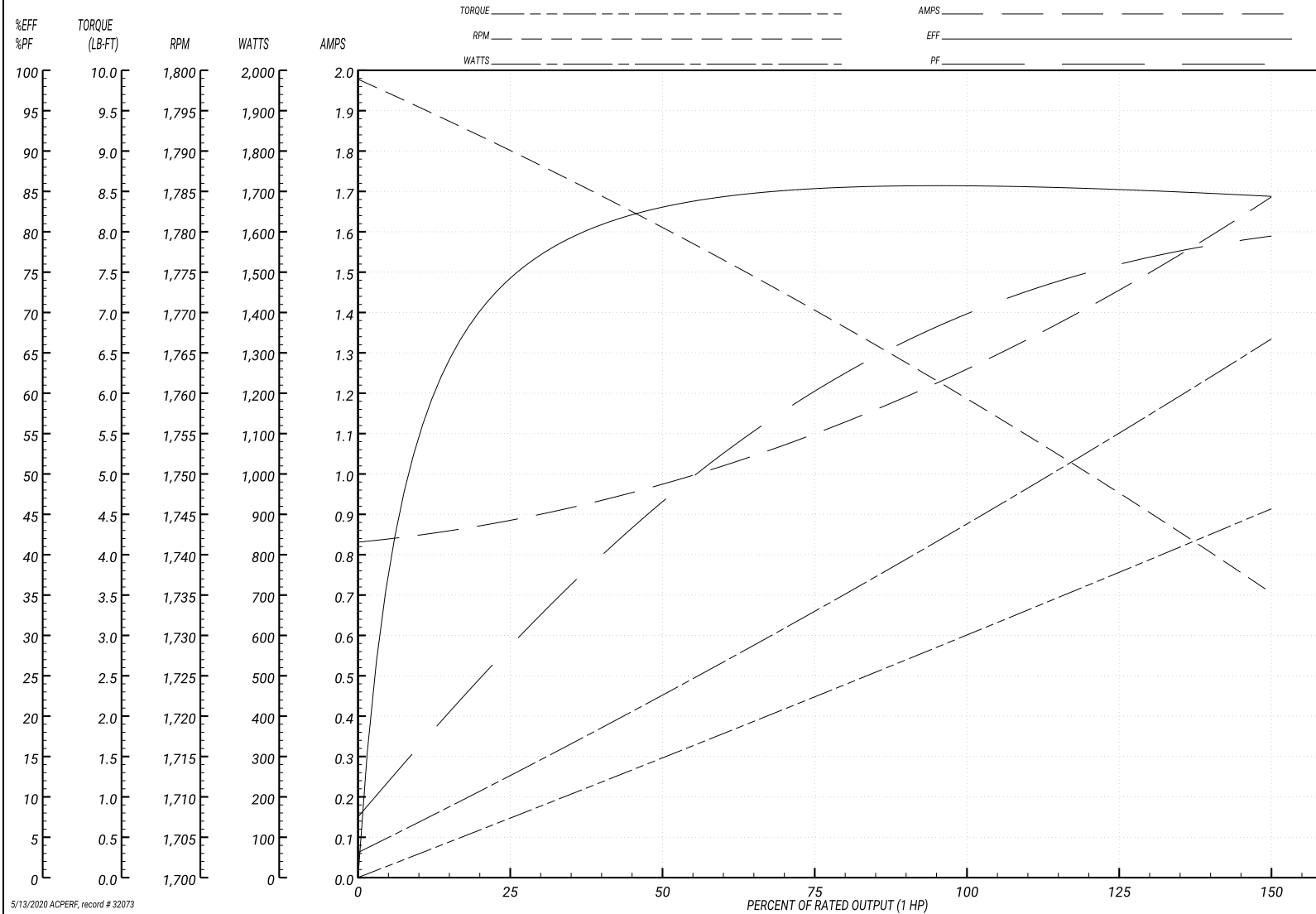

5/13/2020 ACPERF, record # 32073

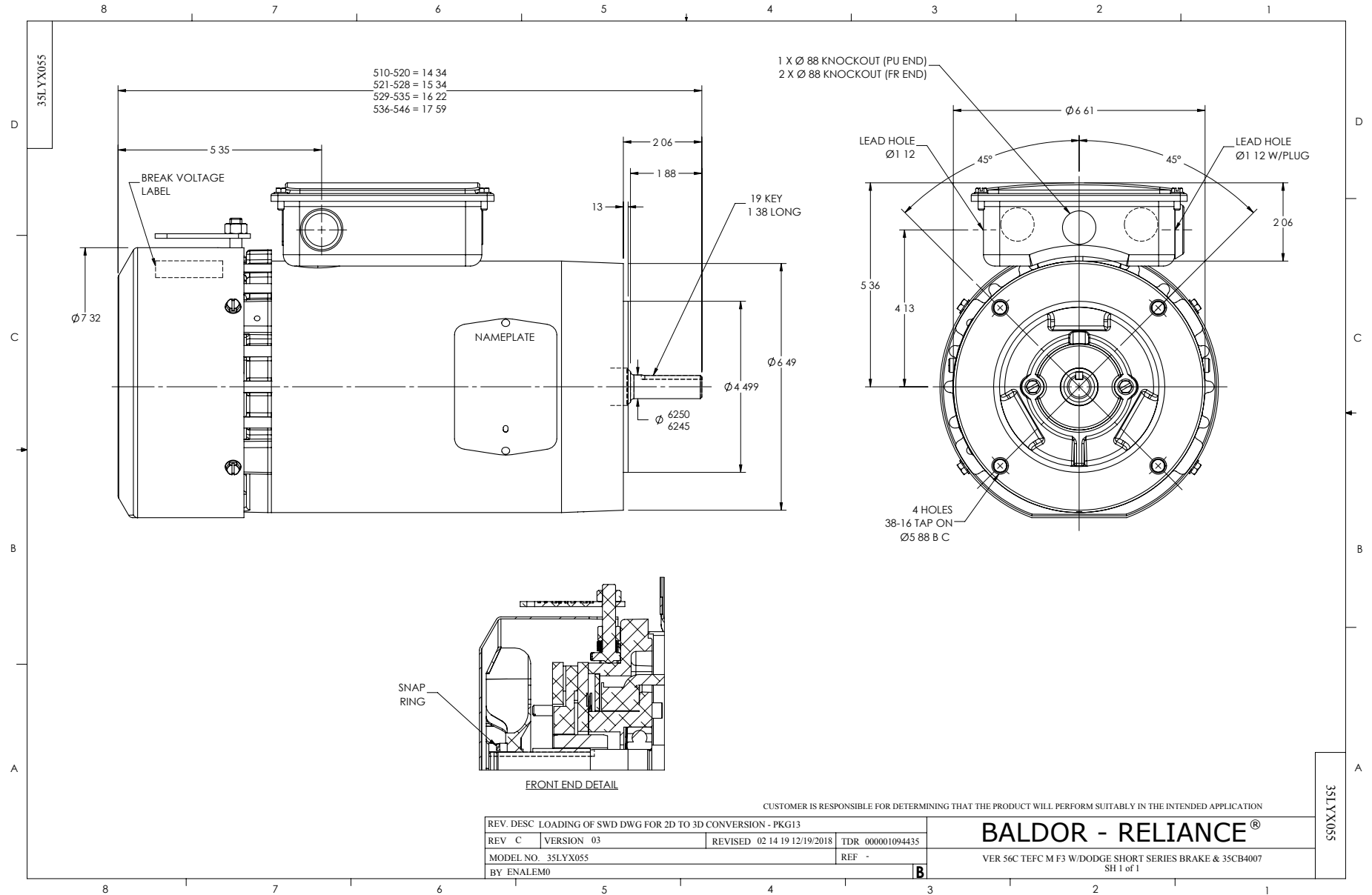

CD0006



NOTES:

1. THREE LEAD MOTOR MAY BE EITHER WYE CONNECTED OR DELTA CONNECTED.
2. INTERCHANGE ANY TWO LINE LEADS TO REVERSE ROTATION.
3. OPTIONAL THERMOSTATS ARE PROVIDED WHEN SPECIFIED.
4. ACTUAL NUMBER OF INTERNAL PARALLEL CIRCUITS MAY VARY.
5. LEAD COLORS ARE OPTIONAL. LEADS MUST BE NUMBERED AS SHOWN.

CD0006

REV. DESC: ADD CLASS CONN00000007		
REV. LTR: E	VERSION: 01	TDR: 000001099922
FILE: \AAA\00005\141	REVISED: 10:24:49 02/19/2019	BY: ENBRIRO
MTL: -	© □	

BALDOR - RELIANCE®

3PH, SV, 3 LEADS, WYE OR DELTA CONNECTED

SH 1 of 1